

DS/EN 1991-1-3 DK NA:2015 - 2nd edition

National Annex to

Eurocode 1: Actions on structures - Part 1-3: General actions - Snow loads

Foreword

This national annex (NA) is a revision of DS/EN 1991-1-3 DK NA:2012 and replaces the latter on 2015-10-15. No technical changes have been made. The changes are purely editorial and are a consequence of the publication of DS/EN 1991-1-3+A1:2015; they consist in changes of μ subscripts and renumbering of figures.

This NA lays down the conditions for the implementation in Denmark of DS/EN 1991-1-3 for construction works in conformity with the Danish Building Act or the building legislation. Other parties can put this NA into effect by referring thereto.

A National Annex contains national provisions, viz. nationally applicable values or selected methods. The Annex may furthermore give complementary, non-contradictory information.

This NA includes:

- an overview of possible national choices and clauses containing complementary information;
- national choices;
- complementary, non-contradictory information;
- text replacing clauses 5.3.6 and 6.2, respectively.

Overview of possible national choices and complementary information

The list below identifies the clauses where national choices are possible and the applicable/not applicable informative annexes. Furthermore, clauses giving complementary information are identified. Complementary information is given at the end of this document.

Clause	Subject	National choice ¹⁾	Complementary information
1.1(2)	Scope - Snow loads for altitudes above 1500 m	Not relevant	
1.1(3)	Scope - Application of Annex A	Not relevant	No exceptional loads are applied
1.1(4)	Scope - Application of Annex B	Not applicable	
2(3)	Classification of actions - Definition of exceptional snow loads	Not relevant	No exceptional loads are applied
2(4)	Classification of actions - Conditions for loads due to excep- tional snow drifts	Not relevant	No exceptional loads are applied
3.3(1)	Exceptional conditions	Not relevant	No exceptional loads are applied
3.3(2)	Exceptional conditions	Not relevant	No exceptional loads are applied
3.3(3)	Exceptional conditions	Not relevant	No exceptional loads are applied
4.1(1) NOTE 1	Characteristic values - Snow load on the ground	National choice	
4.1(1)	Characteristic values - European ground snow load map	Not relevant	
4.1(2)	Characteristic values - Statistical analysis of snow data	Not relevant	
4.2(1)	Other representative values - Load combination values	National choice	
4.3(1)	Treatment of exceptional snow loads on the ground	Not relevant	No exceptional loads are applied
5.2(2)	Load arrangements - Application of Annex B	Not relevant	No exceptional loads are applied
5.2(5)	Load arrangements - Guidance on determining the load arrangements in connection with artificial removal or redistribution of snow loads	No guidance	Removal of snow should not be assumed in the de- sign
5.2(6)	Load arrangements -	No complemen- tary guidance	

Clause	Subject	National choice ¹⁾	Complementary information
	Further complementary guidance in connection with rainfalls at the same time as snow loads		
5.2(7)	Load arrangements - Exposure coefficient C_e	National choice	
5.2(8)	Load arrangements - Thermal coefficient C_t	No complementary guidance	
5.3.1(1)	Roof shape coefficients. General - Alternative load arrangements for snow drift	Not relevant; no exceptional loads are applied	Complementary information
5.3.1(3), Table 5.2	Shape coefficients for roofs	Unchanged	
5.3.2(3)	Monopitch roofs - drifted snow load arrangements	Unchanged	But see Annex F
5.3.3(4)	Snow load shape coefficients. Pitched roofs	National choice	
5.3.4(3)	Snow load shape coefficients. Multi-span roofs - Application of Annex B	Not relevant	No exceptional loads are applied
5.3.4(4)	Snow load shape coefficients. Multi-span roofs - Further guidance	No guidance	
5.3.5(1) NOTE 1	Snow load shape coefficients. Cylindrical roofs - Upper limit of shape coefficients for cylindrical roofs	Unchanged	
5.3.5(1) NOTE 2	Snow load shape coefficients. Cylindrical roofs - Consideration of snow fences	National choice	
5.3.5(3)	Snow load shape coefficients. Cylindrical roofs - Drifting load arrangement	National choice	
5.3.6	Snow load shape coefficients. Roofs abutting and close to taller construction works as well as drifting at projections and obstructions	The entire clause is replaced by a new clause	
5.3.6(1) NOTE 1	Snow load shape coefficients. Roofs abutting and close to taller construction works - Range for μ_w	Cf. above, new clause	
5.3.6(1) NOTE 2	Snow load shape coefficients. Roofs abutting and close to taller construction works - Range for drift length	Cf. above, new clause	

Clause	Subject	National choice ¹⁾	Complementary information
5.3.6(3)	Snow load shape coefficients. Roofs abutting and close to taller construction works - Drifted snow	Cf. above, new clause	
6.2	Local effects	The entire clause is replaced by a new clause 5.3.6	
6.2(2)	Local effects. Drifting at projections and obstructions	Cf. above, new clause	
6.3(1)	Local effects. Snow overhanging the edge of a roof	Unchanged	Snow overhanging the edge of a roof is not applied
6.3(2)	Local effects. Snow overhanging the edge of a roof - Coefficient k	Not applicable	Snow overhanging the edge of a roof is not applied, $k=0$
Annex A Table A.1 NOTE 2	Design situations and load arrangements to be used for different locations	Not applicable	No exceptional loads are applied
Annex B	Snow load shape coefficients for exceptional snow drifts	Not applicable	No exceptional loads are applied
Annex C	European Ground Snow Load Maps	Not applicable	
Annex D	Adjustment of the ground snow load according to return period	Unchanged	
Annex E	Bulk weight density of snow	No choice made	The recommended values are applied
Annex F	Alternative drifted snow load arrangements		Complementary information
Annex G	Roof valleys		Complementary information

¹⁾

Unchanged: The recommendation in the Eurocode is followed.

No choice made: The Eurocode does not recommend values or methods, but allows the option of determining national values or methods.

Not applicable The Annex is not applicable.

Applicable: The Annex is applicable in Denmark and has the same status as specified in the Eurocode.

National choice: A national choice has been made.

Not relevant: Not applicable in Denmark.

National choices

4.1 (1) NOTE 1 Characteristic values - Snow load on the ground

Characteristic ground snow load value $s_k = 1,0 \text{ kN/m}^2$.

4.2 (1) Other representative values - Load combination factors

Values equal to those specified in the Danish National Annex to DS/EN 1990 are chosen.

5.2(7) Load arrangements – Exposure coefficient C_e

The exposure coefficient, C_e , depends on the topography of the surroundings and the size of the structure, and is determined by:

$$C_e = C_{\text{top}} C_s$$

where

C_{top} is the topography coefficient
 C_s is the size coefficient.

The coefficient C_{top} is obtained using Table 5.1.a NA.

Table 5.1.a NA – Recommended values of C_{top} for different topographies

Topography	C_{top}
Windswept ^{a)}	0,8
Normal ^{b)}	1,0
Sheltered ^{c)}	1,25

^{a)} *Windswept topography*: Flat unobstructed areas exposed on all sides without, or little shelter afforded by terrain, higher construction works or trees. The topography can be taken as wind-swept when the structure is at least 15 m higher than local shelters in the surrounding terrain. It is particularly decisive to evaluate the conditions in the case of exposure to wind from eastern directions – see Figure 5.2.c NA.

^{b)} *Normal topography*: Areas where there is no significant removal of snow by wind on construction works because of terrain, other construction works or trees.

^{c)} *Sheltered topography*: Areas in which the construction being considered is considerably lower than the surrounding terrain or surrounded by high trees and/or by higher construction works.

The coefficient C_s is obtained by:

For sheltered topography:

$$C_s = 1,0$$

For windswept and normal topographies, where l_1 and l_2 are the lengths of the longer and shorter sides, respectively, of the building:

For $2h > l_1$ (cf. Figure 5.0.b NA):

$$C_s = 1,0$$

For $2h \leq l_1$ (cf. Figure 5.0.b NA):

$$\begin{array}{ll}
 C_s = 1 & \text{for } l_2 \leq 10h \\
 C_s = 1 + 0,025 \cdot \frac{l_2 - 10h}{h} & \text{for } 10h < l_2 < 20h \\
 C_s = 1,25 & \text{for } l_2 \geq 20h
 \end{array}$$

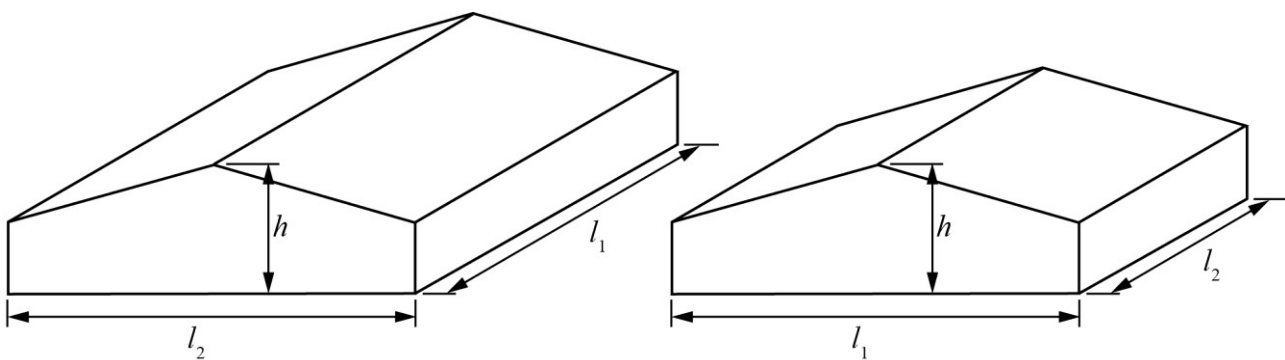

Figure 5.0.b NA – Building dimensions

5.3.3(4) Snow load shape coefficients. Pitched roofs

For structures exposed to wind and snow, an additional load arrangement is taken into account by applying a shape factor of zero for the windward side and μ_w for the leeward side of the roof as shown in Figure 5.2.b NA. The load arrangement allows for an exceptional amount of drifted snow due to wind on the leeward side of the roof when all of the conditions mentioned below are fulfilled:

- the orientation of the building shall be as shown in Figure 5.2.c NA;
- the height of the windward side of the building does not exceed 10 m;
- 2 times the ridge height, h , is smaller than the crosswind dimension of the building, l , see Figure 5.2.c NA, i.e. $2h < l$;
- the depth of the building, b , is larger than the ridge height of the building, h , see Figure 5.2.b NA, i.e. $b > h$;
- the windward terrain is an open area which corresponds to a terrain roughness of category II according to DS/EN 1991-1-4 (Table 4.1) at a distance of 400 m.

The rules in clause 5.3.3(4) are not to be combined with the rules for roof valleys specified in Annex G.

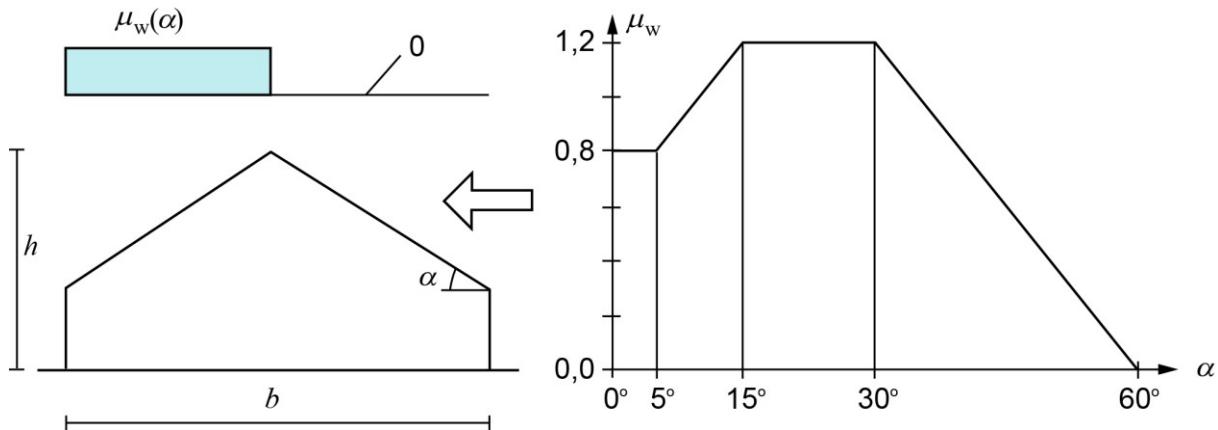

Figure 5.2.b NA – Snow load shape coefficient for leeward side depending on roof slope

The shape coefficient, μ_w , obtained from Figure 5.2.b NA, may be calculated using the following expressions:

$\mu_w = 0,8$	for $0^\circ \leq \alpha \leq 5^\circ$
$\mu_w = 0,6 + 0,04\alpha$	for $5^\circ < \alpha < 15^\circ$
$\mu_w = 1,2$	for $15^\circ \leq \alpha \leq 30^\circ$
$\mu_w = 2,4 - 0,04\alpha$	for $30^\circ < \alpha < 60^\circ$
$\mu_w = 0$	for $60^\circ \leq \alpha$

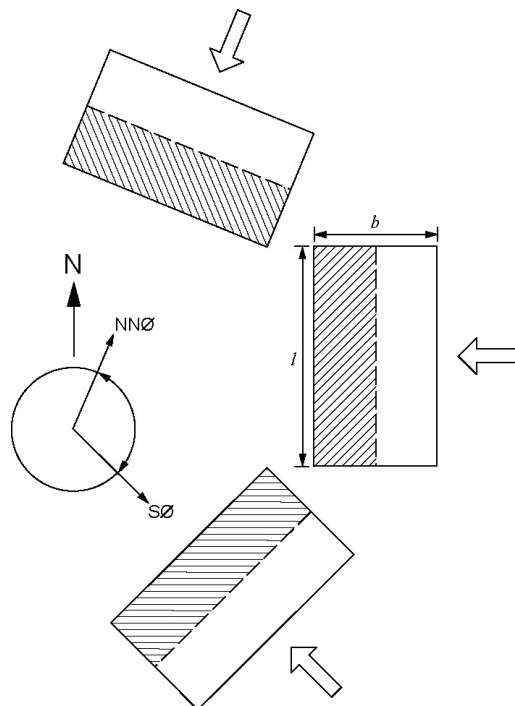

Figure 5.2.c NA – Drifted snow on leeward side of the roof (hatched area) is assumed to occur only when the windward side faces directions from NNE to SE, corresponding to significant drifting when wind comes from easterly directions only

5.3.5(1) NOTE 2 Snow load shape coefficients. Cylindrical roofs – Consideration of snow fences

Where snow fences or other structural parts prevent snow from sliding down the roof, the snow load should be increased.

5.3.5(3) Snow load shape coefficients. Cylindrical roofs - Drifted snow load arrangement

For cylindrical roofs, the drifted snow load arrangement in figure 5.6 in DS/EN 1991-1-3:2007 is supplemented by the following load arrangement shown in Figure 5.5.b NA and Figure 5.5.c NA.

For $\beta_0 \leq 60^\circ$, triangular drifting distribution is assumed, taken as zero at the ridge and using the shape coefficients μ_4 and $\mu_4/2$, respectively, at the line separating the roof and the vertical faces. For $\beta_0 > 60^\circ$, triangular drifting distribution is assumed, taken as zero at the ridge and using the shape coefficients μ_4 and $\mu_4/2$, respectively, where $\beta = 60^\circ$. For $\beta > 60^\circ$, the shape coefficient is 0.

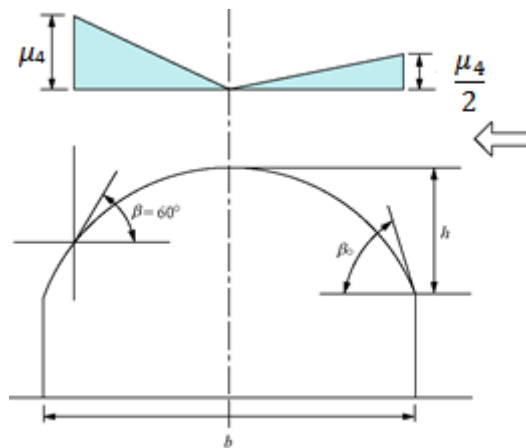

Figure 5.5.b NA – Snow load shape coefficient for a cylindrical roof slope $\beta_0 > 60^\circ$

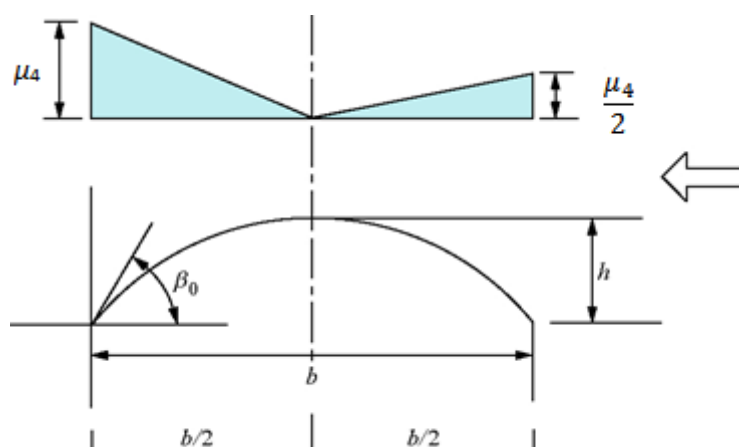

Figure 5.5.c NA – Snow load shape coefficient for a cylindrical roof slope $\beta_0 \leq 60^\circ$

5.3.6 Snow load shape coefficients. Roofs abutting and close to taller construction works as well as drifting at projections and obstructions

(1)NA The structure afforded shelter from the wind is illustrated in Figure 5.6.a NA. It is assumed that $\alpha_w > -5$ and $\alpha_l > -5$. Global shelters have a decisive effect on the wind flow around the entire structure. Local shelters only affect the wind flow around the shelter. The rules given in this clause apply when 2 times the height of the shelter is smaller than the horizontal crosswind dimension of the shelter. If this condition is not fulfilled, the wind will primarily flow around the shelter and drifting be reduced.

NOTE - Equivalent rules also apply to smaller buildings abutting or close to cylindrical buildings.

(2)NA The parameter a determines whether the shelter is local ($a \leq 0,2$) or global ($a \geq 0,4$) and is obtained using the expression

$$a = \max \left\{ \frac{h_{sw}^2}{b_w h_w}, \frac{b_w}{25 h_w} \right\}$$

where (see also Figure 5.6.a NA):

h_w is the height of the windward face; h_w is not taken as lower than 1,5 m;
 b_w is the distance from the height of the windward face of the shelter;
 h_{sw} is the height of the face of the shelter for $\alpha_{sw} \leq 60^\circ$. For $\alpha_{sw} = 90^\circ$, h_{sw} is taken as the ridge height. For $60^\circ < \alpha_{sw} < 90^\circ$, h_{sw} is obtained by interpolation.

(3)NA Snow load shape coefficients for structures with shelters are given by the following expressions and are shown in Figure 5.6.a NA:

μ_2 is taken from table 5.2 of DS/EN 1991-1-3/A1, applying the roof slopes considered
 $\mu_3 = \mu_s + \mu_w$ (5.7)

where

μ_s is the snow load shape coefficient due to snow sliding from the upper roof;
 μ_w is the snow load shape coefficient due to wind. This shape coefficient depends on the specific weight density of snow, γ , which is taken as 2 kN/m³ for this calculation.

(4)NA For the **windward** face of a shelter the following applies, see Figure 5.6.a NA:

$$l_{sw} = \min \{ b_w; 2h_{sw} \} \quad \text{but } 5 \text{ m} \leq l_{sw} \leq 15 \text{ m}$$

$$\mu_{ww} = h_{sw} \frac{\gamma}{s_k} \quad \text{but } \mu_{ww} \geq \mu_1$$

$$\begin{array}{ll} \mu_{ww} \leq 2 & \text{but } a \leq 0,2 \\ \mu_{ww} \leq 10a & \text{but } 0,2 < a < 0,4 \\ \mu_{ww} \leq 4 & \text{but } a \geq 0,4 \end{array}$$

(5)NA For the **leeward** face of a shelter the following applies, see Figure 5.6.a NA:

$$l_{sl} = 5 h_{sl} \quad \text{but } 5 \text{ m} \leq l_{sl} \leq 15 \text{ m og } l_{sl} \leq b_1$$

$$\mu_{wl} = h_{sl} \frac{\gamma}{s_k} \quad \text{but } \mu \leq \mu_{wl} \leq 2$$

$$\mu_{wl} = 0 \quad \text{if } h_{sl} < 0,5 \text{ m}$$

$$\mu_{sl} = 0 \quad \text{if } h_{sl} < 0,5 \text{ m}$$

$$\mu_{sl} = 0 \quad \text{for } \alpha_{sl} \leq 15^\circ$$

$$\mu_{sl} = \mu_1(\alpha_{sl}) b_{sl} / l_{sl} \quad \text{for } \alpha_{sl} > 15^\circ$$

NOTE - NOTE - For low values of h_{sw} , the load case in Annex F, F(3), may govern the design.

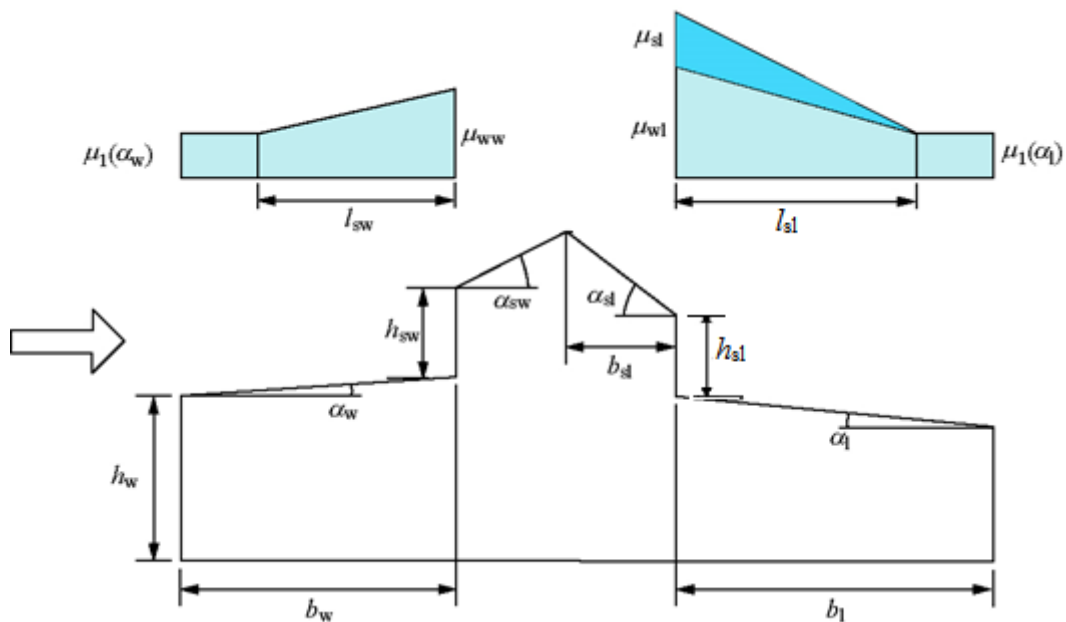

Figure 5.6.a NA Structure with shelter where the windward face height is h_{sw} and the leeward face height is h_{sl}

(6) NA If the leeward side of a roof has several local shelters, the leeward load shall be increased in certain cases. This is taken into account by applying an additional load arrangement when all of the conditions mentioned below are fulfilled:

- the orientation of the building shall be as shown in Figure 5.2.c NA;
- the height of the windward side of the building does not exceed 10 m;
- 2 times the ridge height, h , is smaller than the crosswind dimension of the building, l , see Figure 5.7.a NA, i.e. $2h < l$;
- the shelters are at least 0,5 m high;
- the free distance, l_v , between shelters is between 3 and 7 times their width, v ;
- shelters are located on the leeward side.

The shape coefficient, μ_w , for the additional load arrangement is obtained from:

$$\begin{array}{ll} \mu_w = 1,0 & \text{for } 0^\circ \leq \alpha \leq 35^\circ \\ \mu_w = 1 - (\alpha - 35)/25 & \text{for } 35^\circ < \alpha < 60^\circ \\ \mu_w = 0 & \text{for } 60^\circ \leq \alpha \end{array}$$

The load is applied to the leeward face of the shelters, see Figure 5.7.a NA.

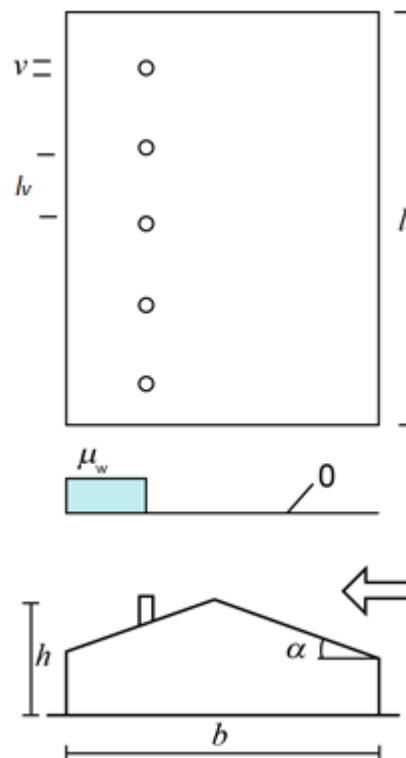

Figure 5.7.a NA Closely spaced local shelters with wind from easterly directions, cf. Figure 5.2.c NA

If the free distance between the shelters is 10 times the shelter width, ($l_v \geq 10v$), the load case in Figure 5.7.a NA may be disregarded. If the free distance is between 7 and 10 times the shelter width, ($7v < l_v < 10v$), the shape coefficient, μ_w , is determined by linear interpolation.

If the free distance is 0, the shape coefficient, μ_w , is determined by applying the rules in clause 5.3.6(5) NA. If the free distance is between 0 and 3 times the shelter width, ($0 < l_v < 3v$), the shape coefficient, μ_w , is determined by linear interpolation.

The rules regarding local shelters are to be combined neither with the rules in clause 5.3.3(4), nor the rules for roof valleys specified in Annex G.

Annex A, Table A.1, Note 2 Design situations and load arrangements to be used for different locations – Application of Annex B (exceptional snow loads)

Exceptional snow falls or snow drifts are not assumed for Denmark; therefore no instructions are given for cases B1 and B3.

Complementary (non-contradictory) information

5.3.1(1) Shape coefficients. General. Alternative snow drift load arrangements

NOTE - Drifted snow loads are furthermore to include the specifications in Annex F.

Annex F Alternative drifted snow load arrangements

(1)NA For structures susceptible to snow load variations, e.g. cantilevered structures and structures susceptible to torsion, a load case is examined where half of the snow load is taken as a fixed action and the other half of the snow load is taken as a free action.

(2)NA The same partial coefficient is applied for the fixed part and the free part of the snow load.

For cantilevered roofs, examples include the following load cases:

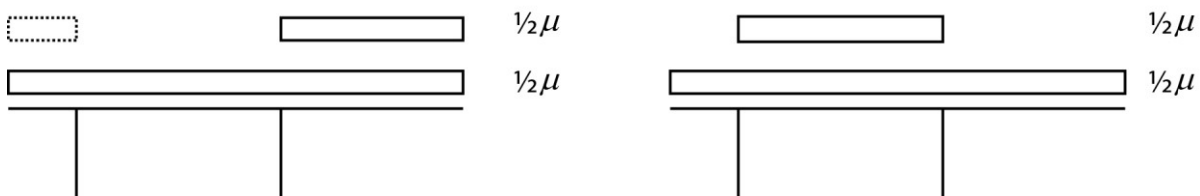

Figure F.1 NA Structure with cantilever

For a structure susceptible to torsion, examples include the following load cases:

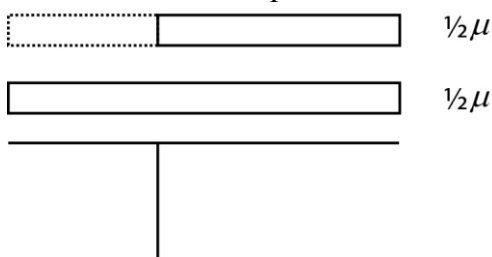

Figure F.2 NA Structure susceptible to torsion

NOTE - $\mu = \mu_1$

(3)NA For a roof where the slope is reduced from α_2 to α_3 , see Figure F.3 NA, the risk of snow loads due to drifting can be taken into account as illustrated in the figure. Case (ii) is equivalent to case (ii) in DS/EN 1991-1-3, clause 5.3.4 (3), which is applied if $\alpha_3 < 0$.

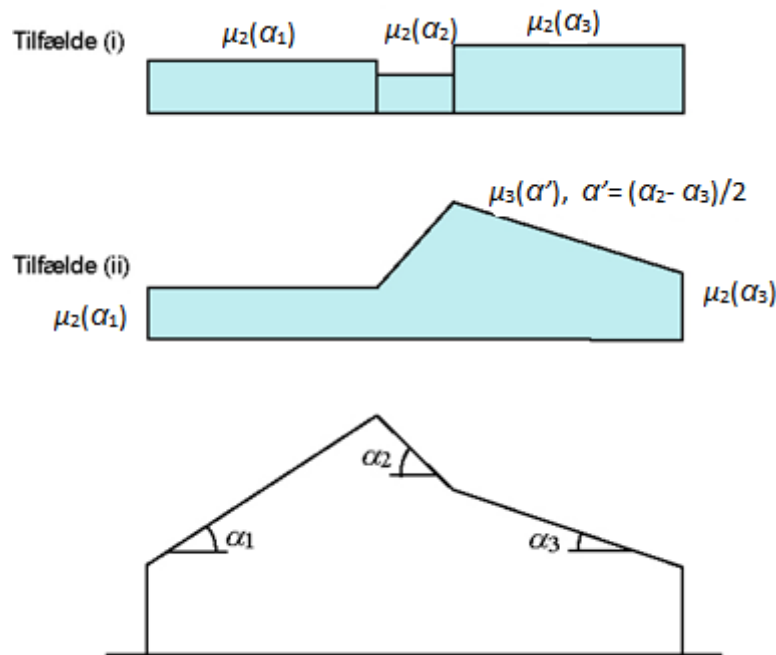

Figure F.3 NA – Shape coefficient for roofs with change of slope

Annex G Roof valleys

(1)NA At roof valleys, drifting may occur both at the windward and the leeward sides.

The rules given below apply for buildings where the horizontal projection of the roof valley $l \geq 10$ m, and where $b_1 \geq 2h_1$ or $b_2 \geq 2h_2$; the symbols appear from Figure G.1 NA.

(2)NA Drifting is assumed in the hatched area in Figure G.1 NA. Drifting may occur on both sides simultaneously or on one side only.

(3)NA Within the hatched area the shape coefficient is increased from μ_2 to μ_3 as shown in Figure G.1.NA, where μ_2 and μ_3 are the shape coefficients according to clause 5.3.3(2). For μ_3 , the value of the larger of the angles of roof pitch is applied.

NOTE 1 - The rule applies to monopitch as well as pitched roofs.

NOTE 2 - For structures that are not susceptible to asymmetric snow loads (e.g. structures not susceptible to torsion), it will be conservative to take the shape coefficient as μ_3 for the entire hatched area.

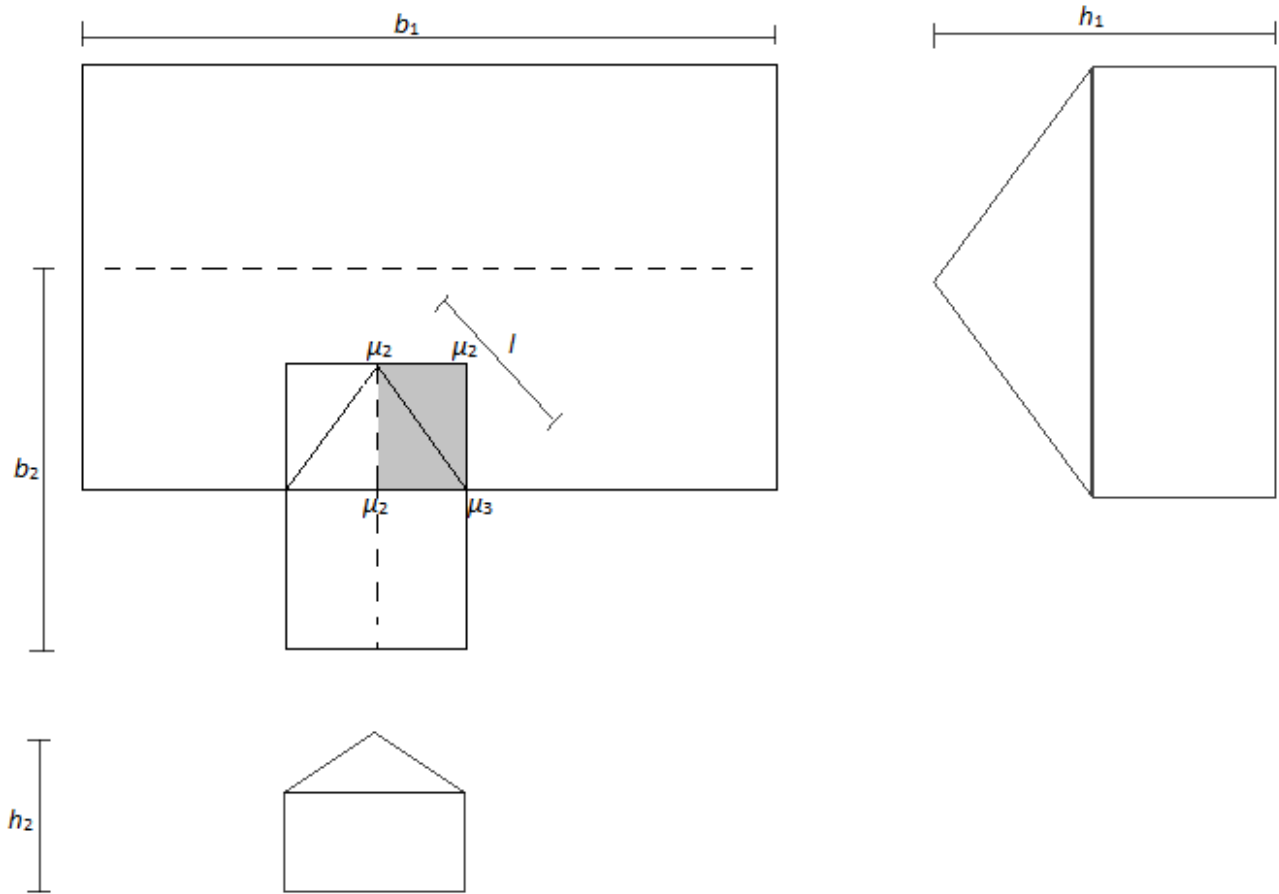

Figure G.1 NA Structure with roof valleys. The area for which increased shape coefficients apply is marked